

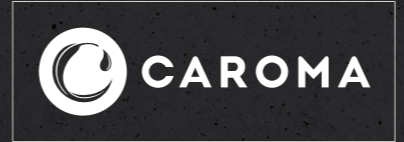

# Elvire

BATHROOM COLLECTION



The Caroma Elvire Collection represents the pinnacle of over 80 years of master craftsmanship in bathroom design. Featuring distinct bespoke solutions, delivering an experience of unsurpassable luxury. At the leading edge of global bathroom design, this Elvire range encapsulates the best of modern Australian ingenuity and innovation.

Caroma marks a new benchmark in bathroom luxury with its unique combination of intuitive design, beautiful aesthetics and environmentally sustainable solutions.

"Carefully crafted, the Elvire collection is where nature and luxury unite. It brings together a minimalist design aesthetic with beautiful materials for a stunning bathroom experience."



- Luke Di Michiel,  
Caroma Industrial Designer



# Elvire

Caroma is proud to introduce the Elvire bathroom collection.

We've paired beautiful sustainable Tasmanian timbers with sophisticated gunmetal finishes to create a unique collection that is grounded in practical, functional and sustainable design principles.

The Elvire collection includes innovative enamelled steel basins and beautiful timber accents which invite touch and interaction, whilst ensuring the highest level of quality and luxury.

The result is a collection that reflects our unique connection to the Australian environment and Caroma's passion for progressive Australian design.





TASMANIAN OAK

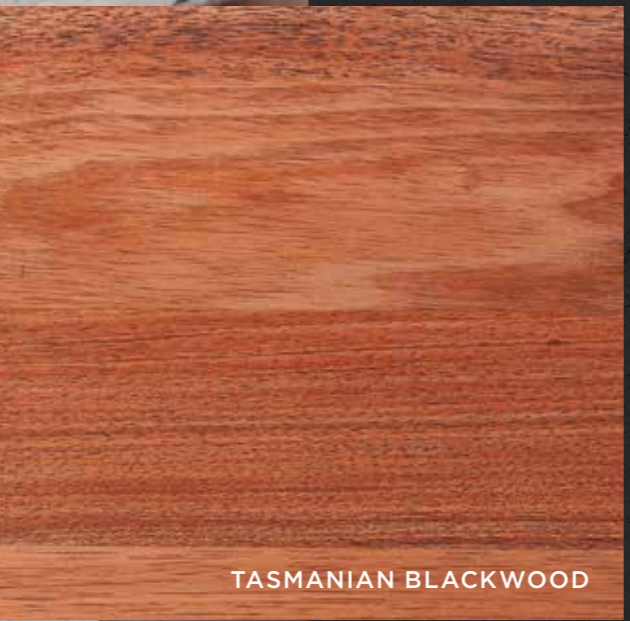

TASMANIAN BLACKWOOD

# Created with sustainability in mind

At Caroma we pride ourselves on utilising renewable and recyclable materials to help support a sustainable future.

Our Elvire collection showcases a beautiful selection of locally grown and sustainably sourced Tasmanian timbers, passionately crafted in celebration of Australia's natural environment.

Tasmanian Oak and Tasmanian Blackwood have been selected for their natural beauty and versatility throughout the collection. The Elvire bathroom collection is like no other.



# An award-winning collection

The **Caroma Elvire Collection** has been awarded the prestigious **Good Design Award Gold** accolade in the **Product Design Hardware and Building** category in recognition for outstanding design and innovation.

The annual Good Design Awards is Australia's oldest and most prestigious international Awards for design and innovation with a proud history dating back to 1958. The Awards celebrate the best new products and services on the Australian market, excellence in architectural design, engineering, fashion, digital and communication design, design strategy, social impact design and young designers.

More than 55 Good Design Awards Jurors evaluated the entry according to a strict set of design criteria which covers 'good design', 'design innovation' and 'design impact'. Projects recognised with a Good Design Award must demonstrate excellence in good design and convince the Jury they are worthy of recognition at this level.





The Elvire range of vanities and basins have been *reimagined* to create a considered and complete *integrated design solution*.

## Vanities & basins

Featuring your choice of Tasmanian Oak or Tasmanian Blackwood, our vanities in the Elvire collection are crafted from sustainable timbers, manufactured locally in Australia. The premium timbers are finished with a satin seal, with no staining, to accentuate the natural beauty of the product.

The distinct thin edged basins are made with enamelled steel and crafted with precision for complete symmetry and a flawless fit. The range includes a variety of styles and sizes across both vanities and basins.

- Designed and engineered in Australia
- Made with quality hard-wearing enamelled steel
- Available in right or left hand shelf options (vanities and wall basin)
- Includes an integrated shroud to conceal plumbing (vanities and wall basin)
- Includes a spacious and practical drawer with premium soft close runners (vanities)
- Includes an integrated pop down plug and waste
- 400mm width - 10L capacity
- Timber is sealed with a premium two-pack polyurethane finish for durability and water resistance





A highlight of the collection is the *luxurious* overhead rain shower which provides the perfect design match to the basins and bath.

## Showers

The enamelled steel shroud of the overhead rain shower might just be the star of the show in the Elvire collection. It's more than just a shower head, it is a design feature of its own.

A gunmetal rail shower with overhead and singular gunmetal handheld shower are also available in this range.

- Designed and engineered in Australia
- Satin gunmetal finish with matching hose (rail shower with overhead and handheld shower)
- Minimalist handheld shower design





The *refined edge*  
detail and *high gloss*  
finish make the luxurious  
freestanding bath a real  
standout in the range.

## Baths

Considered by many as the ultimate in relaxation, a luxurious freestanding bath will undoubtedly turn your bathroom into your sanctuary.

Our Elvire bath is crafted using solid surface material, meaning it's highly durable, non-porous, and smooth and warm to the touch.

- Designed in Australia
- Featuring a high gloss finish
- Includes an integrated solid surface pop down waste for a seamless look
- 375L capacity
- Overflow not available







The integration of  
Tasmanian timbers into the  
tapware range exude luxury  
and *natural beauty*.

## Tapware

Striking gunmetal taps come with a metal knurled detailed handle, or combine with your chosen Tasmanian signature timber handle to create a luxury tapware range like none you've seen before.

Available in a bench or wall mounted mixer as well as a stunning bath filler to complement your Elvire bath.

- Designed and engineered in Australia
- Body constructed from quality hard-wearing brass
- Features progressive cartridge technology for accurate temperate flow and control
- Timber is sealed with a premium two-pack polyurethane finish for durability and water resistance





Caroma Cleanflush® is our most effective and hygienic toilet. Our patented design features *revolutionary* rimless technology that delivers the next generation of toilets: easy to clean and water efficient with *superior* hygiene.



## Toilet suites

Every detail has been considered in the Elvire toilet suite range, with gunmetal seat hinges, timber Invisi flush buttons and Caroma's patented Cleanflush® technology.

The range includes both wall hung and wall faced Invisi Series II® as well as a wall faced close coupled option.

- Designed in Australia
- Caroma Cleanflush® - hygienic rimless design
- Includes a quick release soft close seat with hard-wearing PVD finished gunmetal hinges for a consistent design match
- Supplied with Caroma's patented Uni-Orbital® connector for ease of installation, providing superior set-out flexibility during installation





The *crafted timber* details of the Elvire accessory range make an impressive addition to any bathroom.

## Accessories

Our Elvire signature sustainable timbers are incorporated throughout this range of essential accessories, making them the ultimate finishing touches to your stunning Elvire-inspired bathroom.

Elvire accessories include toilet roll holder with shelf, towel rail with shelf, hand towel rail with shelf and robe hook.

- Designed in Australia
- Made from hard-wearing brass with a premium high gloss finish
- Timber shelf available in Tasmanian Oak or Tasmanian Blackwood
- Timber is sealed with a premium two-pack polyurethane finish for durability and water resistance





# Create your *sanctuary*

	<p>① Elvire Freestanding Bath 1700 <b>CAELO062W</b></p> <p>② Elvire Progressive Freestanding Bath Filler - Tasmanian Blackwood Handle <b>CAELO027DW</b></p>	 <p>⑨ Elvire Overhead Rain Shower with Shroud <b>CAELO057GM3A</b></p>
	 <p>③ Elvire 1200 Right Hand Shelf Wall Basin - Tasmanian Blackwood <b>CAELO025WDW</b></p>	 <p>⑩ Elvire Hand Shower <b>CAELO043GM3A</b></p> <p>⑪ Elvire Progressive Bath/Shower Mixer - Tasmanian Blackwood Handle <b>CAELO032DW</b></p>
<p>④ Elvire Progressive Basin Mixer - Tasmanian Blackwood Handle <b>CAELO026DW6A</b></p>	 <p>⑦ Elvire Invisi Series II® Round Dual Flush Plate &amp; Buttons - Tasmanian Blackwood <b>237100WDW</b></p>	 <p>⑫ Elvire Toilet Roll Holder with Shelf with Shelf - Tasmanian Blackwood <b>CAELO046DW</b></p>
 <p>⑤ Elvire Progressive Wall Basin Mixer - Tasmanian Blackwood Handle <b>CAELO028DW6A</b></p>	 <p>⑧ Elvire Cleanflush® Invisi Series II® Wall Hung Toilet Suite <b>847910W</b></p>	 <p>⑬ Elvire Robe Hook <b>CAELO064W</b></p>





# Basins & vanities



**Elvire 900 Right Hand Shelf Wall Basin - Tasmanian Oak**

No taphole CAELO008WLW  
 1 taphole CAELO017WLW  
 No overflow  
 Warranty | 10 year residential, 1 year commercial



**Elvire 900 Left Hand Shelf Wall Basin - Tasmanian Oak**

No taphole CAELO007WLW  
 1 taphole CAELO015WLW  
 No overflow  
 Warranty | 10 year residential, 1 year commercial



**Elvire 1200 Right Hand Shelf Wall Basin - Tasmanian Oak**

No taphole CAELO024WLW  
 1 taphole CAELO025WLW  
 No overflow  
 Warranty | 10 year residential, 1 year commercial



**Elvire 1200 Left Hand Shelf Wall Basin - Tasmanian Oak**

No taphole CAELO016WLW  
 1 taphole CAELO023WLW  
 No overflow  
 Warranty | 10 year residential, 1 year commercial



**Elvire 900 Right Hand Shelf Wall Basin - Tasmanian Blackwood**

No taphole CAELO008WDW  
 1 taphole CAELO017WDW  
 No overflow  
 Warranty | 10 year residential, 1 year commercial



**Elvire 900 Left Hand Shelf Wall Basin - Tasmanian Blackwood**

No taphole CAELO007WDW  
 1 taphole CAELO015WDW  
 No overflow  
 Warranty | 10 year residential, 1 year commercial



**Elvire 1200 Right Hand Shelf Wall Basin - Tasmanian Blackwood**

No taphole CAELO024WDW  
 1 taphole CAELO025WDW  
 No overflow  
 Warranty | 10 year residential, 1 year commercial



**Elvire 1200 Left Hand Shelf Wall Basin - Tasmanian Blackwood**

No taphole CAELO016WDW  
 1 taphole CAELO023WDW  
 No overflow  
 Warranty | 10 year residential, 1 year commercial

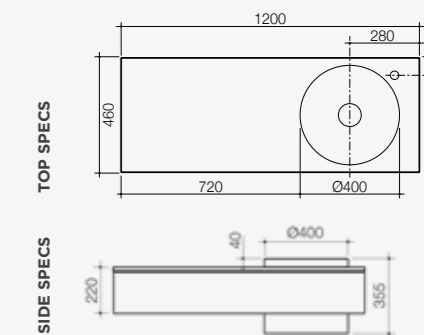
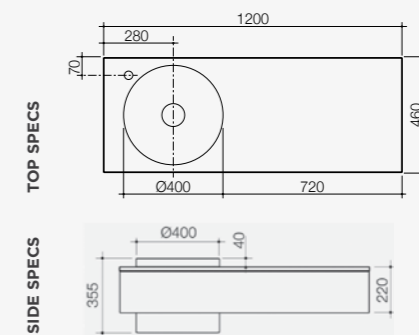
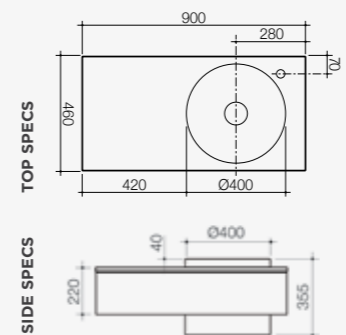
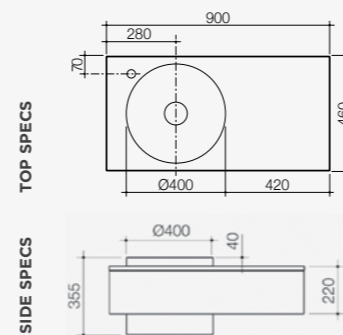



# Basins & vanities



**Elvire 400 Right Hand Shelf Wall Basin - Tasmanian Oak**

CAEL0006WLW  
No overflow  
Warranty | 10 year residential, 1 year commercial



**Elvire 400 Left Hand Shelf Wall Basin - Tasmanian Oak**

CAEL0005WLW  
No overflow  
Warranty | 10 year residential, 1 year commercial



**Elvire 400 Right Hand Shelf Wall Basin - Tasmanian Blackwood**

CAEL0006WDW  
No overflow  
Warranty | 10 year residential, 1 year commercial



**Elvire 400 Left Hand Shelf Wall Basin - Tasmanian Blackwood**

CAEL0005WDW  
No overflow  
Warranty | 10 year residential, 1 year commercial



**Elvire 400 Wall Basin**

CAEL0002W  
No overflow  
Warranty | 10 year residential, 1 year commercial



**Elvire 400 Inset Basin**

CAEL0001W  
No overflow  
Warranty | 10 year residential, 1 year commercial

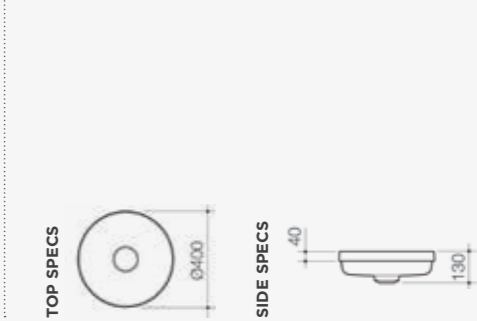
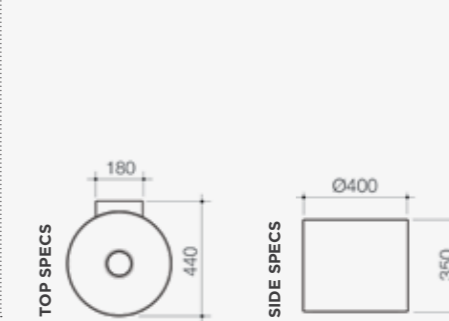
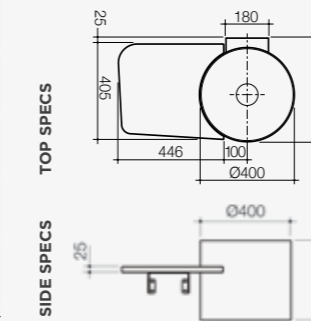
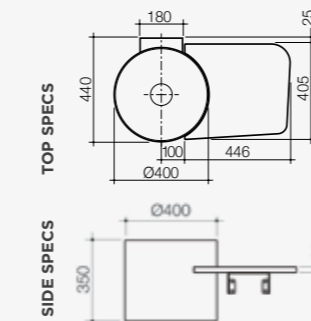



# Showers

## Elvire Overhead Rain Shower with Shroud

WELS 3 star rated, 9L/min  
CAELO057GM3A

Warranty | 10 year residential, 7 year commercial

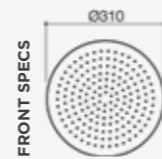

## Elvire Rail Shower with Overhead 300mm

WELS 3 star rated, 9L/min  
CAELO042GM3A

Warranty | 10 year residential,  
7 year commercial

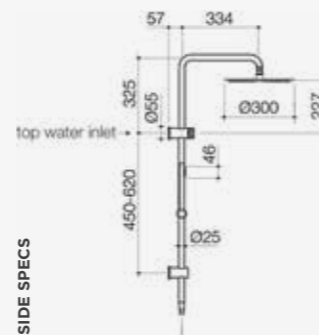

## Elvire Hand Shower

WELS 3 star rated, 9L/min  
CAELO043GM3A

Warranty | 10 year residential,  
7 year commercial

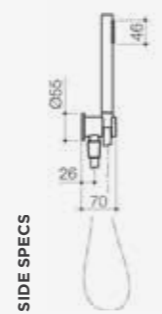

# Bath



## Elvire Freestanding Bath 1700

CAELO062W  
No overflow

Warranty | 10 year residential and commercial

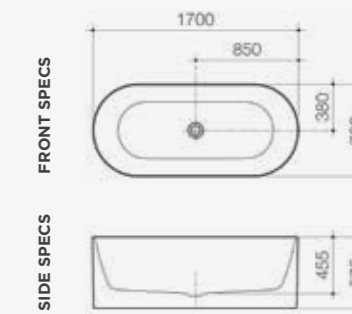



BATH CADDY NOT INCLUDED



# Tapware



**Elvire Progressive Basin Mixer**  
WELS 6 star rated, 4.5L/min

-  Tasmanian Blackwood Handle  
CAELO026DW6A
-  Tasmanian Oak Handle  
CAELO026LW6A
-  Knurled Gunmetal Handle  
CAELO026GM6A

Warranty | 10 year residential and commercial

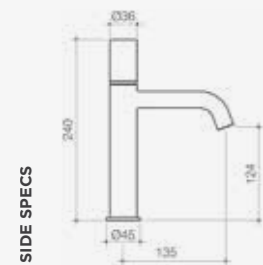

**Elvire Progressive Wall Basin Mixer**  
WELS 6 star rated, 4.5L/min

-  Tasmanian Blackwood Handle  
CAELO028DW6A
-  Tasmanian Oak Handle  
CAELO028LW6A
-  Knurled Gunmetal Handle  
CAELO028GM6A

Warranty | 10 year residential and commercial

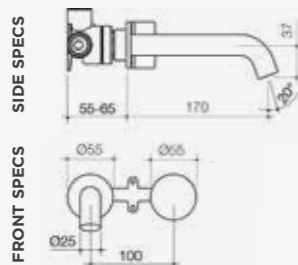

**Elvire Basin Outlet 170mm**  
WELS 6 star rated, 4.5L/min  
CAELO030GM6A  
Warranty | 10 year residential and commercial

Warranty | 10 year residential and commercial

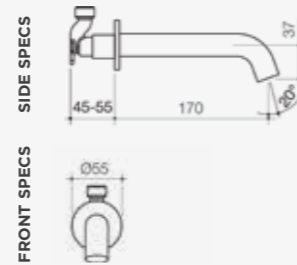

**Elvire Bath Outlet 205mm**  
CAELO031GM  
Warranty | 10 year residential and commercial

Warranty | 10 year residential and commercial

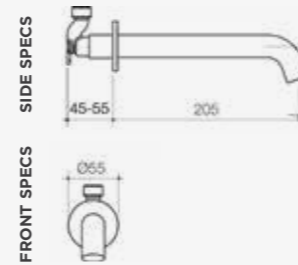

**Elvire Progressive Bath/Shower Mixer**  
WELS 6 star rated, 4.5L/min

-  Tasmanian Blackwood Handle  
CAELO032DW
-  Tasmanian Oak Handle  
CAELO032LW
-  Knurled Gunmetal Handle  
CAELO032GM

Warranty | 10 year residential and commercial

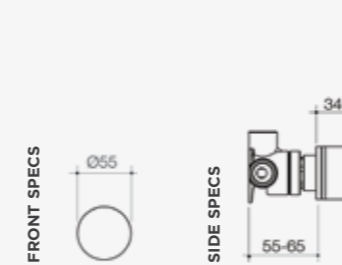

**Elvire Progressive Bath/Shower Mixer with Diverter**

-  Tasmanian Blackwood Handle  
CAELO033DW
-  Tasmanian Oak Handle  
CAELO033LW
-  Knurled Gunmetal Handle  
CAELO033GM

Warranty | 10 year residential and commercial

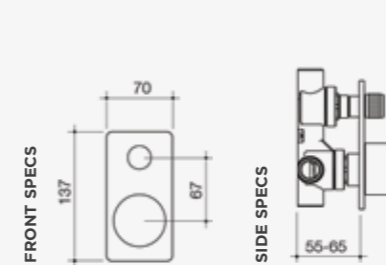

**Elvire Progressive Freestanding Bath Filler**

-  Tasmanian Blackwood Handle  
CAELO027DW
-  Tasmanian Oak Handle  
CAELO027LW
-  Knurled Gunmetal Handle  
CAELO027GM

Warranty | 10 year residential and commercial

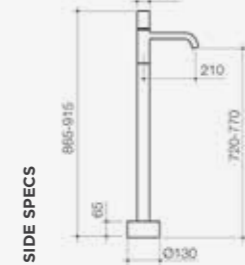



**FLOW SPLITTER**  
Precise flush stream effectively clears the bowl



**FLOW CHANNELS**  
Controlled water flow eliminates splash back



**FLOW BALANCER**  
Powerful flush for whole bowl clean

# Toilet suites



## Elvire Cleanflush® Invisi Series II® Wall Hung Toilet Suite

WELS 4 star rated, 4.5/3 (3.5L average flush)  
 Inceiling, inwall 847910W  
 Undercounter 847920W  
 Structural brick wall 847930W

*Invisi Series II® flush buttons sold separately*

Warranty | 10 year residential and commercial



## Elvire Cleanflush® Invisi Series II® Wall Faced Toilet Suite

WELS 4 star rated, 4.5/3 (3.5L average flush)  
 846310W

*Invisi Series II® flush buttons sold separately*

Warranty | 10 year residential and commercial



## Elvire Cleanflush® Wall Faced Toilet Suite - Back Entry

WELS 4 star rated, 4.5/3 (3.5L average flush)  
 846210W

Warranty | 10 year residential and commercial



## Elvire Invisi Series II® Round Dual Flush Plate & Buttons - Tasmanian Oak

237100WLW

Warranty | 1 year residential and commercial



## Elvire Invisi Series II® Round Dual Flush Plate & Buttons - Tasmanian Blackwood

237100WDW

Warranty | 1 year residential and commercial

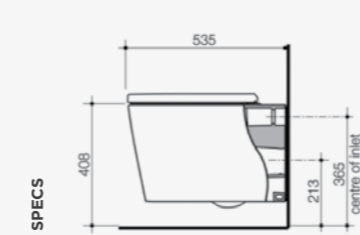

**SPECS**

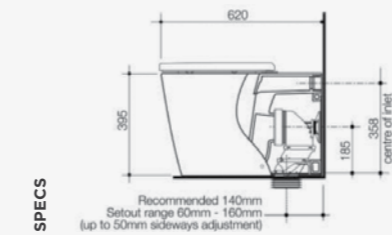

**SPECS**

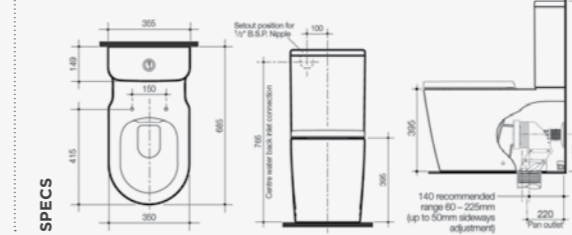

**SPECS**

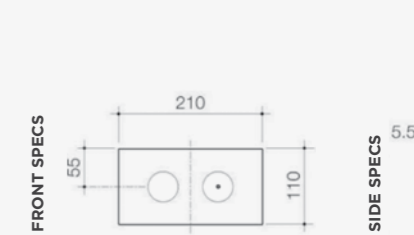

**FRONT SPECS**

**SIDE SPECS**

# Accessories



**Elvire Toilet Roll Holder with Shelf - Tasmanian Oak**

CAEL0046LW

Warranty | 5 year residential, 1 year commercial



**Elvire Hand Towel Rail 300mm with Shelf - Tasmanian Oak**

CAEL0048LW

Warranty | 5 year residential, 1 year commercial



**Elvire Towel Rail 700mm with 300mm Shelf - Tasmanian Oak**

CAEL0047LW

Warranty | 5 year residential, 1 year commercial



**Elvire Robe Hook**

CAEL0064W

Warranty | 5 year residential, 1 year commercial



**Elvire Toilet Roll Holder with Shelf - Tasmanian Blackwood**

CAEL0046DW

Warranty | 5 year residential, 1 year commercial



**Elvire Hand Towel Rail 300mm with Shelf - Tasmanian Blackwood**

CAEL0048DW

Warranty | 5 year residential, 1 year commercial



**Elvire Towel Rail 700mm with 300mm Shelf - Tasmanian Blackwood**

CAEL0047DW

Warranty | 5 year residential, 1 year commercial

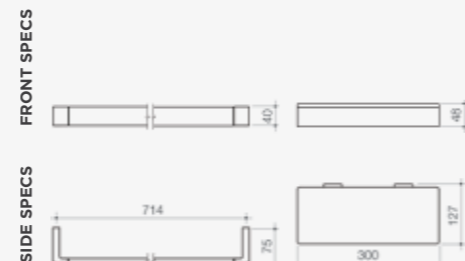
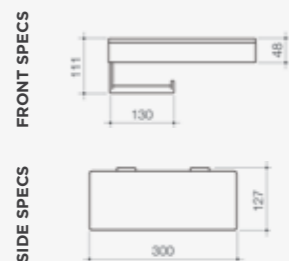





With over 80 years of experience, Caroma believes that quality bathrooms have to be a balance of form, function and looks. Bathrooms are spaces where we put a personal touch on our homes. Caroma enables you to enjoy bathroom experiences that both complement and elevate your lifestyle, from an energising morning start to an indulgent, relaxing moment of luxury.

Designed for Australians and New Zealanders from all walks of life with different tastes and needs, Caroma's wide range of classic to artisanal styles, smart designs and sustainable innovations provide you with everything you need to create the *sanctuary of your dreams.*

[www.caroma.com.au](http://www.caroma.com.au) | [www.caroma.co.nz](http://www.caroma.co.nz)

© Copyright 2019. Caroma Industries Ltd. ABN 35 000 189 499. All rights reserved. Material and design specifications subject to change without notice. Product colour reproduction is as near to actual product colour as production methods allow. Warning: Products in this brochure are the subject of registered designs and patents. ® is a registered trademark of Caroma Industries. This brochure relates to Australian products only and some product, design or specifications may differ in other countries.